

STAINLESS STEEL 316L PRESS FIT FITTINGS (M PROFILE)

COMPLY WITH BSEN1254-2: 1998

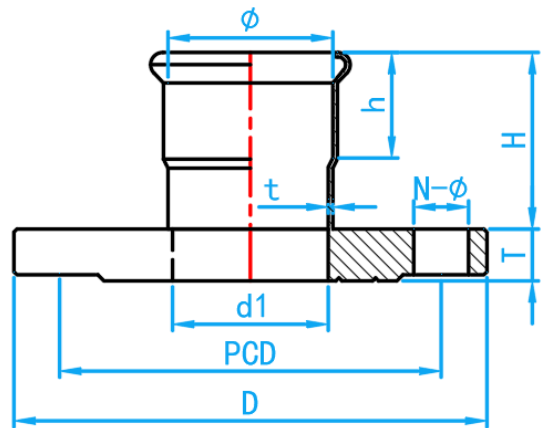

PRESSFIT FLANGE SOCKET



CROSS SECTIONAL VIEW

DIMENSIONS

STOCK CODE	Ø (mm)	D (mm)	PCD (mm)	d1 (mm)	NO.S OF HOLS	d (mm)	T (mm)	H (mm)	h (mm)	t (mm)	WEIGHT (kg)
SS316LPFNFLS01515*	15	95	65	12	4	14	14	31	20	1.5	0.640
SS316LPFNFLS02020*	22	105	75	18	4	14	16	35	21	1.5	0.940
SS316LPFNFLS02525	28	115	85	25	4	14	16	40	23	1.5	1.140
SS316LPFNFLS03535	35	130	100	32	4	18	18	45	26	1.5	1.840
SS316LPFNFLS04242	42	140	110	39	4	18	18	54	31	1.5	2.150
SS316LPFNFLS05050	54	155	125	51	4	18	19	67	36	1.5	2.720
SS316LPFNFLS06565	67	175	145	72	4	18	18	67	50	1.8	3.640
SS316LPFNFLS08080	76	190	160	85	8	18	20	73	51	2.0	4.140
SS316LPFNFLS100100	108	210	180	104	8	18	22	86	75	2.0	4.710

*This item requires special ordering. Please consult with a salesperson for the estimated lead time.